

1. General Description

The EMS4000 is a bidirectional low-power dual port, high-speed, USB 2.0 analog switch with integrated protection for USB Type-C™ systems. The device is configured as a dual 2:1 or 1:2 switch. It is optimized for use with the USB 2.0 DP/DM lines in a USB Type-C™ system.

The device integrates over-voltage protection on the C0+/- pins can withstand up to DC 30V with automatic shutoff circuitry in order to protect system components behind the switch. GPIO controls of SEL and $\overline{\text{EN}}$ are 1.8V logic compatible.

The EMS4000 is available in UQFN 1.4x1.8-10L and UQFN 1.5x2.0-10L package with Pb-free and Halogen-free making it a perfect candidate for mobile and space constrained applications.

2. Features and Benefits

- Wide Supply Range from 2.5 V to 5.5 V
- Differential 2:1 or 1:2 Switch/Multiplexer
- Up to DC 30V Overvoltage Protection (OVP) on C0+/- Ports
- IEC 64000-4-5 Surge Protection w/o External TVS onto C0+/- Ports: ± 30 V
- System Side Clamp Voltage Pulse Less than 8 V, Duration Less than 300 ns
- Power off Protection When $V_{DD} = 0$ V
- 10 Ω typical ON resistance
- Insertion loss: -1dB@200MHz, -2dB@650MHz, -3dB@1GHz
- 6 pF typical ON capacitance
- 1.8 V Compatible Control Logic Inputs
- ESD protection: HBM ESDA/JEDEC JS-001 Class 3A exceeds 4000 V
- Specified from 0°C to 85°C

3. Applications

- USB Type-C™, Type A and Micro B devices
- Mobile Phones, Tablets and Notebooks

4. Ordering Information

Table 1. Ordering information

Type number	Topside marking	Package		Quantity
		Name	Description	
EMS4000RSW	4000YYWW	UQFN1.4×1.8-10L	UQFN package, 10 pins 1.4 mm × 1.8 mm; 0.55 mm (Max) height	3000
EMS4000RSE	4000YYWW	UQFN1.5×2.0-10L	UQFN package, 10 pins 1.5 mm × 2.0 mm; 0.6 mm (Max) height	3000

5. Functional Diagram

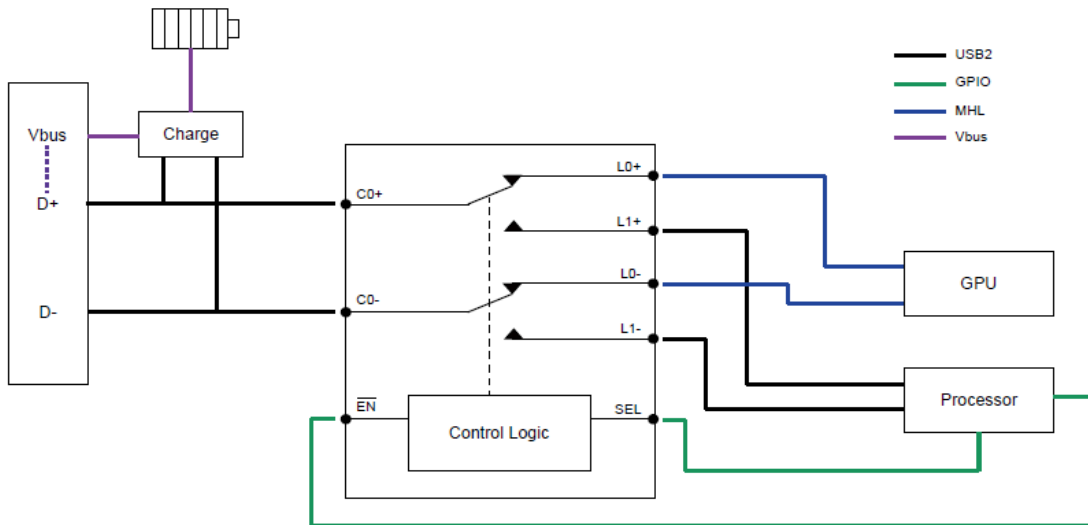
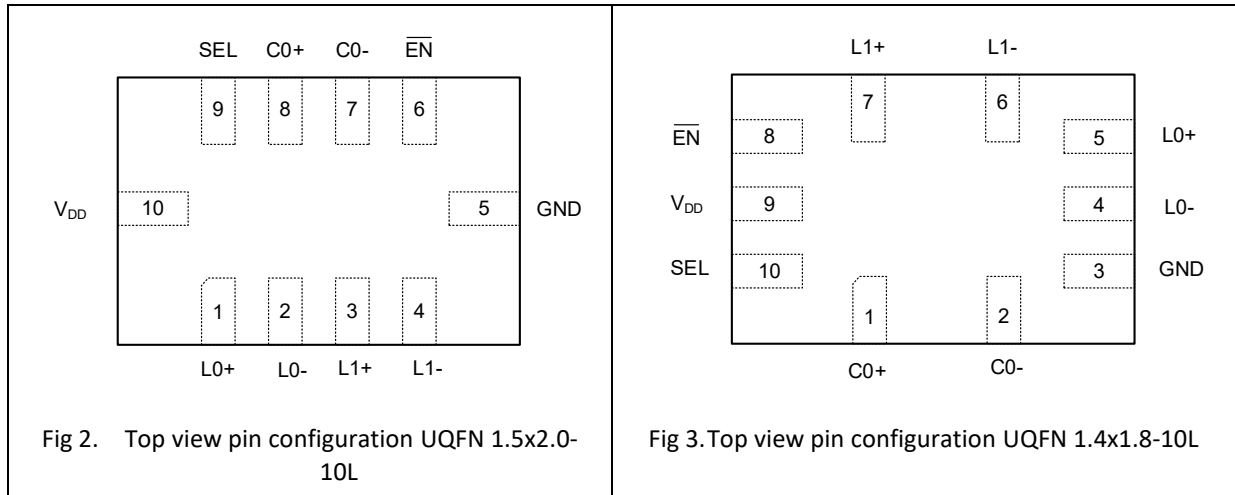

Fig 1. Functional diagram

6. Pinning Information

6.1. Pin map



6.2. Pin description

Table 2. Pin description

Symbol	Pin		Signal Type	Description
	UQFN1.4x1.8-10L	UQFN1.5x2.0-10L		
C0+	1	8	I/O	Signal I/O, Common Port
C0-	2	7	I/O	Signal I/O, Common Port
L1+	7	3	I/O	Signal I/O, Channle 1
L1-	6	4	I/O	Signal I/O, Channle 1
L0+	5	1	I/O	Signal I/O, Channle 0
L0-	4	2	I/O	Signal I/O, Channle 0
SEL	10	9	I	Operation Model Select; (when SEL=0: C0->L0, when SEL=1: C0->L1)
\overline{EN}	8	6	I	$\overline{EN} = 1$, Power Down is Enabled
V _{DD}	9	10	PWR	Positive Supply Voltage
GND	3	5	GND	Power Ground